

CATALOGUE 2016-2017

OUTDOOR POWER EQUIPMENT



Husqvarna Zenoah Co.,Ltd.

1-9 Minamidai, Kawagoe, Saitama, Japan
Telephone: +81 49 243 1117

Copyright © 2014 Zenoah. All rights reserved.
Zenoah and other product and feature marks are trademarks
of the Zenoah Division as displayed at www.zenoah.net.



www.zenoah.net

Distributor:

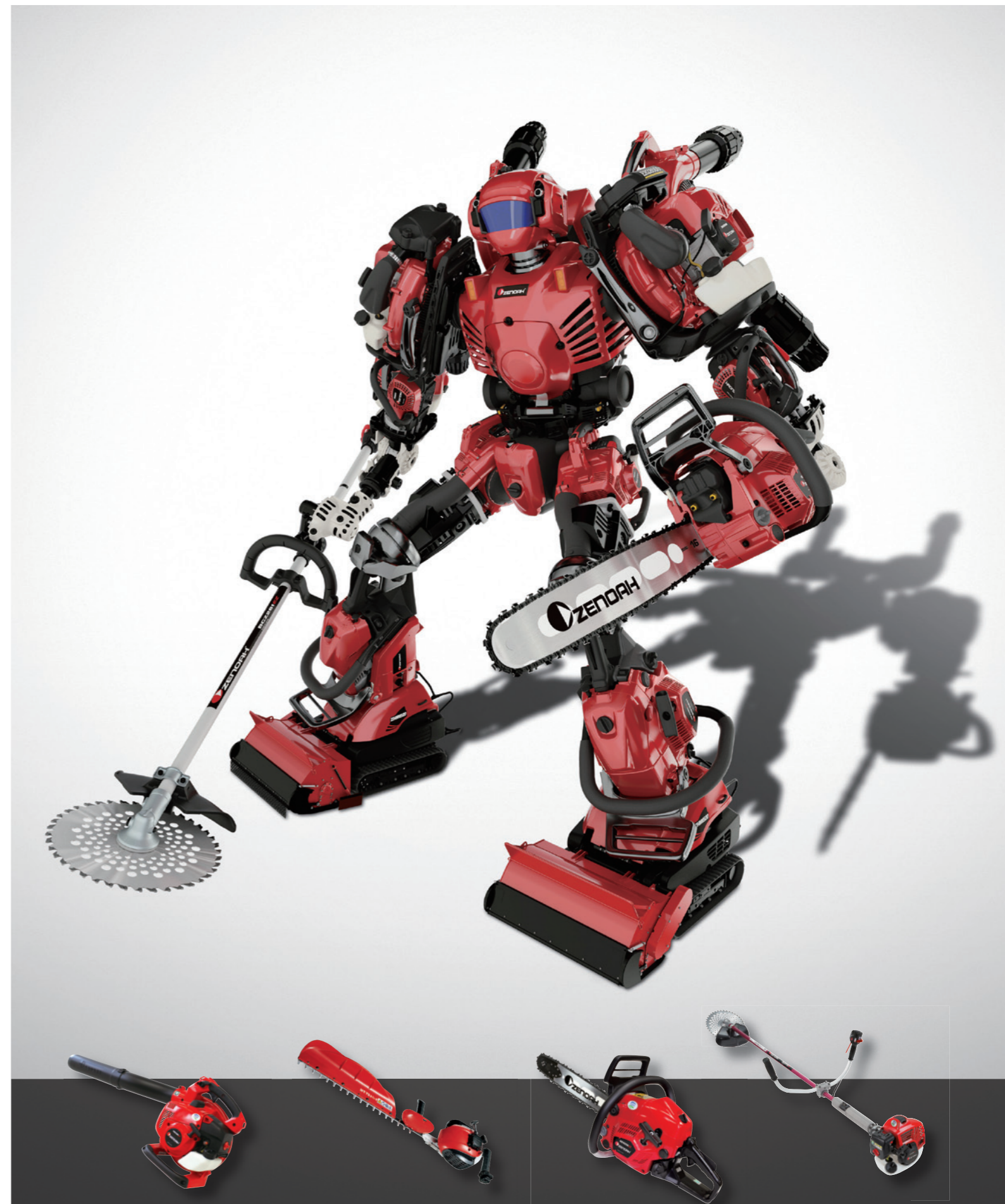

- Our technology 3
- Trimmers/Brushcutters** 5
 - Straight shaft 7
 - Knapsack 9
 - Combination trimmer 11
 - Reciprocator 11
 - Technical information 12
- Chainsaws** 13
 - Top-handle saws 15
 - All-round saws 16
 - Compact professional saws 17
 - Robust saws 17
 - Pole saws 17
 - Technical information 18
- Blowers** 19
 - Handheld blowers 21
 - Backpack blowers 21
 - Technical information 22
- Hedge trimmers** 23
 - Single sided hedge trimmers 25
 - Double sided hedge trimmers 25
 - Short reach trimmers 26
 - Long reach trimmers 26
 - Technical information 27
- Engine drills** 28
- Earth augers** 28
- Dusters/Misters** 29
- Power sprayers** 29
- Chipper shredders** 30
- Flail mowers** 30
- Accessories** 31

Zenoah conducts continuous product development and reserves the right to change designs, specifications and equipment levels without prior notification. All products with moving parts can be dangerous if used improperly. Therefore, always read the instructions carefully. Equipment and performance can vary from market to market. Ask you dealer about available equipment and performance in your market. All technical data was current at time of printing. However such data is subject to change due to product development. We cannot accept responsibility for printing errors.

With you, with nature

In Japan, a country with four beautiful and distinct seasons, we at Zenoah have been working hand in hand with our customers, constantly refining our technologies to help them protect our green spaces.

The agriculture, forestry, and landscape gardening professionals who are our customers are at the forefront of efforts to conserve our green landscapes and natural environment. Proud, confident, and hard-working yet humble and often quiet, they perform tasks like tree-thinning in forests to promote future growth and managing natural elements to help our outdoor environments thrive.

At Zenoah, we understand these professionals and wish to remain their trusted partner. All our products are designed and built with this wish in mind. We will continue to push forward, supporting our customers by staying behind them, every step of the way.



Zenoah Warrior swings into action!

Our corporate mascot, Zenoah Warrior, embodies our corporate slogan, "With you, with nature." His body parts are chainsaws, brushcutters, and other examples of Zenoah's latest products. The mission of Zenoah Warrior is to support agriculture, forestry, and landscape gardening professionals, following them wherever and whenever they go.

Nature Protection Robot
Zenoah Warrior





Leading in Environmentally Adapted Technology

Zenoah, a manufacturer of outdoor power equipment, has a great interest and responsibility in developing the environmentally adopted products to protect our environment. We pursue economic efficiency for the users while also protecting the environment, we try to bring the environmentally-compatible products to achieve the "Ecology" and "Economy" in the same time.

Our sincere attitude for the environment has successfully developed the Strato-Charged® engine, which passed the world's first California Air Resources Board (CARB) the secondary emission control without a catalyst. We continuously have developed innovative technology into our quality products.



Clean & Economical Strato-Charged® engine

The Strato-Charged® engine passed the world's first California Air Resources Board (CARB) the secondary emission control without a catalyst.

Special features of the Strato-Charged® engine

- Produces low emissions that meet regulations without the need for a heated, heavy catalytic converter
- Requires no valve adjustments, oil changes or daily oil reservoir level checks
- Generates 15 to 20% more horsepower than a typical 4-stroke or 4-stroke hybrid engine of the same engine displacement size

High-performance Strato-Charged® engine

Zenoah's Strato-Charged® 2-stroke engines operate at maximum efficiency with just three moving parts. By comparison, 4-stroke or 4-stroke hybrid engines contain as many as 30 moving parts. Zenoah Strato-Charged® 2-stroke engines are 20 to 25% lighter per same engine size as compared to 4-strokes or 4-stroke hybrids, resulting in much less operator fatigue. Engines with a high power to weight ratio and a high-power output per engine cc size are classified as high-performance engines, and these are the only type of engines made by Zenoah.

Special features of the Strato-Charged® engine

Power

Power equivalent to a conventional 2-stroke engine

Clean

Clean exhaust emissions and reduction in gas odors

Economy

Remarkable reduction in fuel consumption - 30% over conventional 2-stroke engines

Operation without a catalyst

To protect the environment, ZENOAH does not use catalysts that generate extra heat and sacrifice engine performance.

The Strato-Charged® engine conforms easily to strict California State emissions standards

For hand-carried engines with a displacement of less than 50 cc

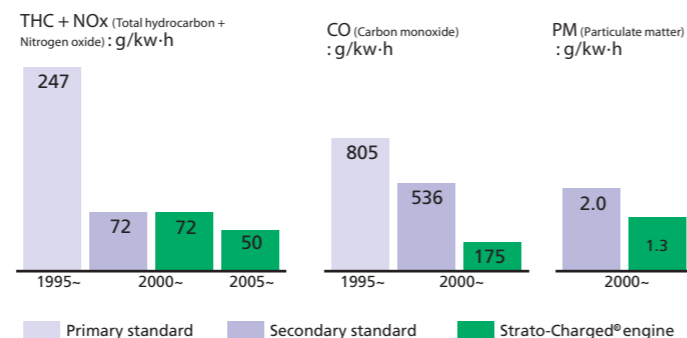

Operating principle of the Strato-Charged® engine

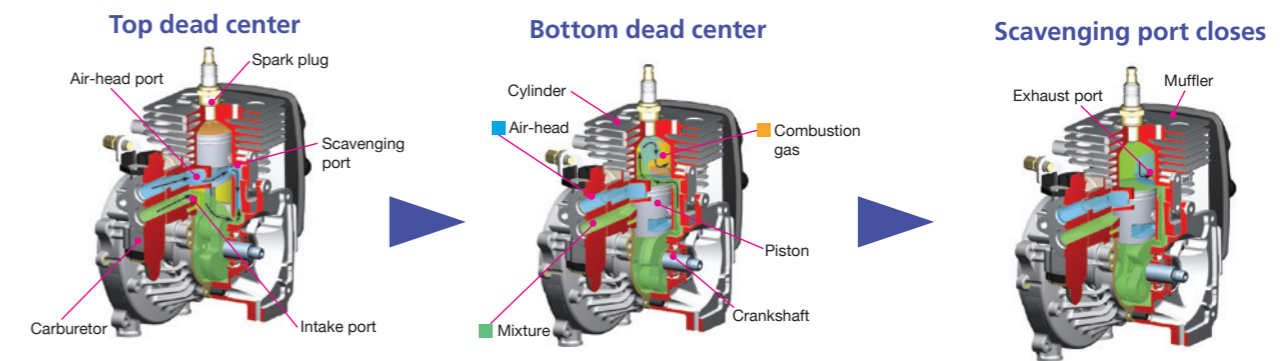

As the piston proceeds through the upstroke of the intake stroke, the crankcase vacuum sucks the lead air in through the scavenging port via the groove on the piston skirt.

As the piston begins its down stroke after top dead center, a scavenging port starts to open and lead air in the cylinder is pushed out through the scavenging port moves into the cylinder earlier than the air-fuel mixture

As the piston begins its upstroke after bottom dead center, burnt gas in the cylinder is pushed out through the exhaust port by lead air. Therefore, almost no air-fuel mixture is emitted.



Trimmers / Brushcutters

Zenoah offers a wide range of trimmers and brushcutters for every application, our comprehensive range covers for the full time landscapers and forest professionals, as well as the occasional user of homeowners. Our products provide more power with light weight and easy handling features.



Easy to start

"Super e-START" reduces recoil pulling force and makes it smoother in pulling operation.

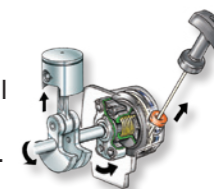

Light weight

The ZENOAH engine starts easily, and accelerates quickly. Engine weight is lighter, in comparison of its performance level.



Tough

Features a heat-treated, tough gearcase with a seal to stop the grease leakage. With a shape specially designed to prevent catching on grass, grease can be also supplied very easily thanks to the bolt opposite to the grease nipple.

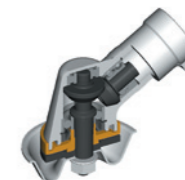

Powerful

The strato-charged® engine produces the optimal power to work effectively. It also meets the emission standards for less emission.

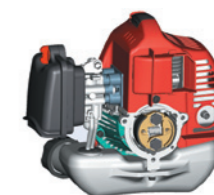

Low vibration

Anti-vibration spring damper absorbs vibration and amplitude. It reduces the vibration transmitted to the users.



Durability

Wrap-around stand, antidust net, and pro-grade paper air cleaner hold up in heavy use.



Features shown are available on applicable models.

Trimmers / Brushcutters

Application marks

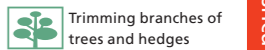
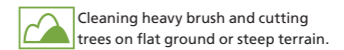
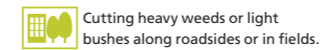
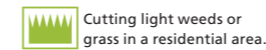

Straight shaft



Light weight, extremely powerful.

BC2611LE

Displacement **25.4cm³**
Power 0.8kW(1.1Hp)
Dry weight 5.1kg



Dual handle model of BC2611LE.

BC2611WE

Displacement **25.4cm³**
Power 0.8kW(1.1Hp)
Dry weight 5.3kg

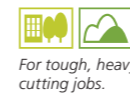

For tough, heavy-duty cutting jobs.

BC4501WE

Displacement **41.5cm³**
Power 1.5kW(2.0Hp)
Dry weight 7.8kg



High power but comfortable use by swivel shaft.

BC4500DW

Displacement **41.5cm³**
Power 1.5kW(2.0Hp)
Dry weight 8.0kg



Perfect for professional use. Float type carburetor.

BC4301FW

Displacement **41.5cm³**
Power 1.5kW(2.0Hp)
Dry weight 7.4kg



Dependable starting, high-performance, durable.

BC3501LE

Displacement **33.6cm³**
Power 1.2kW(1.6Hp)
Dry weight 7.1kg

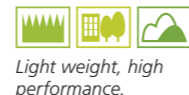
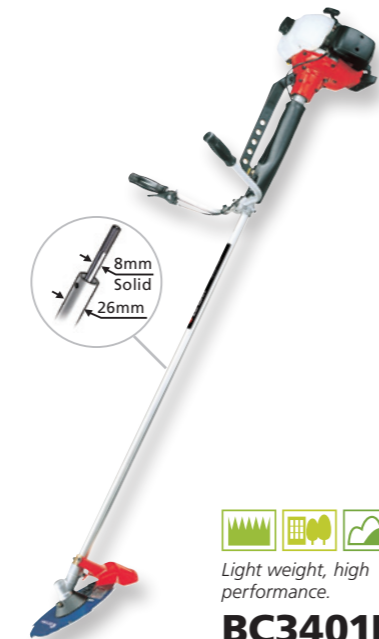

Light weight, high performance.

BC3401FW

Displacement **33.6cm³**
Power 1.1kW(1.5Hp)
Dry weight 7.1kg



Perfect for professional use. Diaphragm carburetor.

BC4350DW

Displacement **41.5cm³**
Power 1.5kW(2.0Hp)
Dry weight 7.6kg

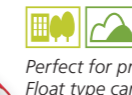

Perfect for professional use. Float type carburetor.

BC4350FW

Displacement **41.5cm³**
Power 1.5kW(2.0Hp)
Dry weight 7.8kg



Perfect for professionals who want superb reliability.

BCZ5050DW

Displacement **50.6cm³**
Power 2.3kW(3.1Hp)
Dry weight 9.2kg



Straight shaft

| Model | BC2611LE | BC2611WE | BC3501LE | BC3401FW |
|------------------------------|-----------|-----------|-----------|--------------|
| Engine model | G26LS | G26LS | G35L | G35L |
| Displacement cm ³ | 25.4 | 25.4 | 33.6 | 33.6 |
| Power kW (Hp) | 0.8(1.1) | 0.8(1.1) | 1.2(1.6) | 1.1(1.5) |
| Dry weight kg | 5.1 | 5.3 | 7.1 | 7.1 |
| Handle | Loop | Dual | Loop | Dual |
| Carburetor | Diaphragm | Diaphragm | Diaphragm | Float |
| Fuel tank lit | 0.75 | 0.75 | 0.74 | 0.80 |
| Pipe length mm | 1500 | 1500 | 1500 | 1440 |
| Standard cutter | 4" Nylon | 4" Nylon | 4" Nylon | 10"-8T blade |
| Strato-charged engine | - | - | - | - |
| Low vibration | - | - | - | - |

- Non compliant ● Compliant

| Model | BC4501WE | BC4500DW | BC4301FW | BC4350DW | BC4350FW | BCZ5050DW |
|------------------------------|-----------|-----------|----------|-------------------------|--------------|--------------------------|
| Engine model | G45L | G45L | G45L | G45L | G45L | GZ50N |
| Displacement cm ³ | 41.5 | 41.5 | 41.5 | 41.5 | 41.5 | 50.5 |
| Power kW (Hp) | 1.5(2.0) | 1.5(2.0) | 1.5(2.0) | 1.5(2.0) | 1.5(2.0) | 2.3(3.1) |
| Dry weight kg | 7.8 | 8.0 | 7.4 | 7.6 | 7.8 | 9.2 |
| Handle | Dual | Dual | Dual | Dual | Dual | Dual |
| Carburetor | Diaphragm | Diaphragm | Float | Diaphragm | Float | Diaphragm |
| Fuel tank lit | 0.94 | 0.94 | 0.80 | 0.94 | 0.80 | 0.80 |
| Pipe length mm | 1500 | 1500 | 1440 | 1500 | 1500 | 1500 |
| Standard cutter | 4" Nylon | 4" Nylon | 4" Nylon | 4" Nylon / 10"-3T blade | 12"-2T blade | 4" Nylon / 10"-80T blade |
| Strato-charged engine | - | - | - | - | - | - |
| Low vibration | - | - | - | - | - | ● |

- Non compliant ● Compliant

Trimmers / Brushcutters

Knapsack

Application marks

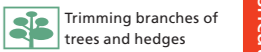
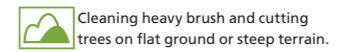
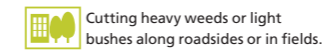
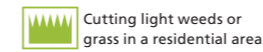

KURU-KURU CUTTER

These newly-developed technologies give the KURU-KURU CUTTER the best operability around!



Strato-Charged® high mileage KURU-KURU CUTTER.

BKZ305L

Displacement **29.5cm³**
Power 1.0kW(1.3Hp)
Dry weight 8.2kg



Newly designed swivel joint and innovative mounting system



Newly designed swivel joint

Both left-handed and right-handed users can operate the machine comfortably.

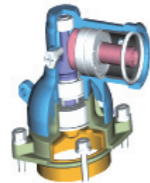

4-point anti-vibration spring

Vibration reduced by 75%.

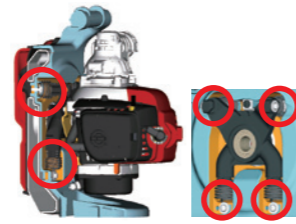

Super e-START Easy to start

"Super e-START" reduces recoil pulling force and makes it smoother in pulling operation.

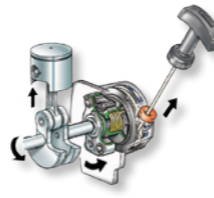

Attachments for the KURU-KURU CUTTER makes changing cutting devices easy!

LHTZ-A

Blade length : 405mm
Angle : 90°

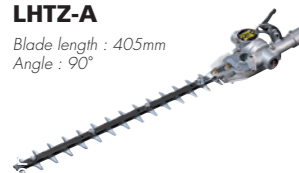

HHTZ-A

Blade length : 300mm
Angle : 90°



SHTZ-A

Blade length : 405mm
Angle : 90°



PSZ-A

Bar : 10"
Chain : 25APJ58E



Light weight high performance knapsack brushcutters.

BK3402FL

Displacement **33.6cm³**
Power 1.1kW(1.5Hp)
Dry weight 9.2kg

BK4302FL

Displacement **41.5cm³**
Power 1.5kW(2.0Hp)
Dry weight 9.4kg



Light weight high performance knapsack brushcutters.

BK3402FLJ

Displacement **33.6cm³**
Power 1.1kW(1.5Hp)
Dry weight 9.4kg

BK4302FLJ

Displacement **41.5cm³**
Power 1.5kW(2.0Hp)
Dry weight 9.6kg



Shaft-joint type



High-quality design, superior usability.

BK3420FL

Displacement **33.6cm³**
Power 1.1kW(1.5Hp)
Dry weight 8.4kg



Light weight high performance knapsack brushcutters.

BK3410FL-S

Displacement **33.6cm³**
Power 1.1kW(1.5Hp)
Dry weight 8.8kg

BK4310FL-S BK4310FL

Displacement **41.5cm³**
Power 1.5kW(2.0Hp)
Dry weight 9.0kg



Clears heavy brush and cuts trees on flat ground or steep terrain.

BKZ5010DL CE

Displacement **50.6cm³**
Power 2.3kW(3.1Hp)
Dry weight 12.0kg



Line head & blade

Both are supplied with each machine.



Safety throttle lever



Ergonomic back pad and cushion strap



Knapsack

| Model | BKZ305L | | | | BK3402 | | | | BK4302 | | | | BK3420FL | BK3410FL-S | BK4310FL-S | BK4310FL | BKZ5010DL |
|-----------------------|-------------|-------|-----|--------|--------------|-------|-----|--------|--------------|-------|-----|--------|-------------|--------------|--------------|--------------|-------------------------|
| | FL | FL-EZ | FLJ | FLJ-EZ | FL | FL-EZ | FLJ | FLJ-EZ | FL | FL-EZ | FLJ | FLJ-EZ | | | | | |
| Engine model | GZ30N | | | | G34L | | | | G43L | | | | G35L | G35L | G43L | G43L | GZ50N |
| Displacement | 29.5 | | | | 33.6 | | | | 41.5 | | | | 33.6 | 33.6 | 41.5 | 41.5 | 50.6 |
| Power | 1.0(1.4) | | | | 1.1(1.5) | | | | 1.5(2.0) | | | | 1.1(1.5) | 1.1(1.5) | 1.5(2.0) | 1.5(2.0) | 2.3(3.1) |
| Dry weight | 8.2 | 9.0 | 9.2 | 9.2 | 9.4 | 9.1 | 9.4 | 9.3 | 9.6 | 8.4 | 8.5 | 8.7 | 9.0 | 12.0 | | | |
| Handle | Loop | | | | Loop | | | | Loop | | | | Loop | Loop | Loop | Loop | Loop |
| Carburetor | Diaphragm | | | | Float | | | | Float | | | | Float | Float | Float | Float | Diaphragm(Cubic) |
| Fuel tank | 1.1 | | | | 1.3 | | | | 1.3 | | | | 1.3 | 1.3 | 1.3 | 1.3 | 1.0 |
| Pipe length | 1380 | | | | 1500 | | | | 750 + 750 | | | | 1380 | 1400 | 1400 | 1500 | 1500 |
| Standard cutter | 10" Tip Saw | | | | 12"-2T blade | | | | 12"-2T blade | | | | 10" Tip Saw | 12"-2T blade | 12"-2T blade | 12"-2T blade | 4" Nylon / 10"-3T blade |
| Super e-start | ● | - | ● | - | ● | - | ● | - | ● | ● | - | ● | - | - | - | - | ● |
| Strato-charged engine | ● | - | - | - | - | - | - | - | - | - | - | - | - | - | - | - | ● |
| Low vibration | ● | - | - | - | - | - | - | - | - | - | - | - | - | - | - | - | - |
| Kuru-kuru cutter | ● | - | - | - | - | - | - | - | - | - | - | - | - | - | - | - | - |

- Non compliant ● Compliant

Trimmers / Brushcutters

Combination trimmer

Presenting a combination trimmer with split-boom attachments! ZENOAH's combination trimmer is composed of the power unit "EX2600PH" and 4 attachments. It handles a variety of greenery jobs, and its disassembling design allows it to be easily stored or transported in the boot of a car.

Split-boom attachments

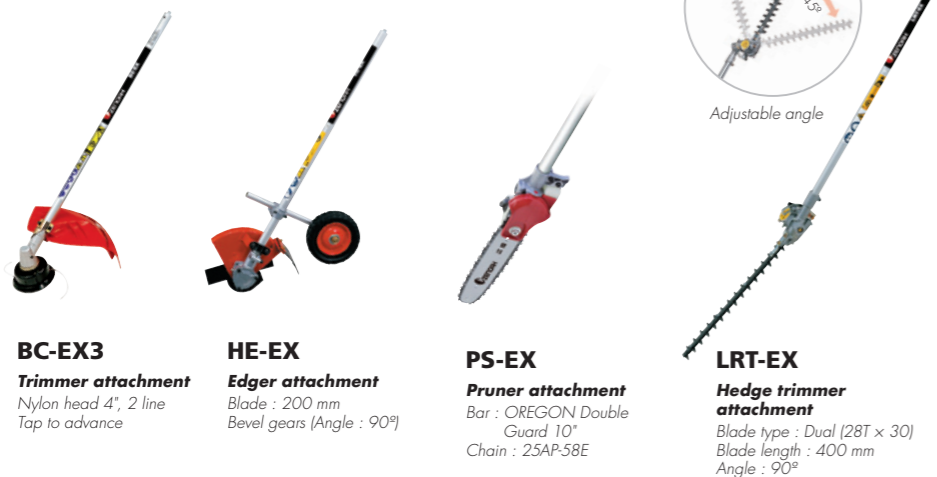

BC-EX3

Trimmer attachment
Nylon head 4", 2 line
Tap to advance

HE-EX

Edger attachment
Blade : 200 mm
Bevel gears (Angle : 90°)

PS-EX

Pruner attachment
Bar : OREGON Double
Guard 10"
Chain : 25AP-58E

LRT-EX

Hedge trimmer attachment
Blade type : Dual (28T x 30)
Blade length : 400 mm
Angle : 90°



Easily attach and detach the attachment.

EX2600PH

Displacement **25.4cm³**
Power 0.8kW(1.1Hp)

Combination trimmer

| Model | EX2600PH(Engine) |
|--------------|----------------------|
| Engine model | G26LS |
| Displacement | cm ³ 25.4 |
| Power | kW (Hp) 0.8 (1.1) |
| Carburetor | Diaphragm |
| Fuel tank | lit 0.75 |

- Non compliant ● Compliant

Reciprocator



Long-selling reciprocator. (Dual handle is also available.)

SGCZ231ST-L

Displacement **22.5cm³**
Power 0.6kW(0.8Hp)
Dry weight 6.3kg

Reciprocator

| Model | SGCZ231ST-L NEW! |
|-----------------|----------------------------|
| Engine model | GZ22S |
| Displacement | cm ³ 22.5 |
| Power | kW (Hp) 0.6 (0.8) |
| Dry weight | kg 5.8 |
| Handle | Loop |
| Carburetor | Rotary Valve |
| Fuel tank | lit 0.5 |
| Standard cutter | 9"-20T Reciprocating blade |

- Non compliant ● Compliant

Liberation from debris and kickback

With conventional trimmers, be prepared for at least two critical drawbacks: debris scattered about by the rotary cutter, and machine kickback when striking stones, trees or other fixed objects. Enter the reciprocator, a powerful new trimmer engineered to eliminate these nagging concerns. Ideal for yard and garden use, the reciprocator is also unsurpassed for trimming around fences, walls, trees, flower beds, golf courses, rivers or ponds.



Application marks

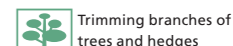
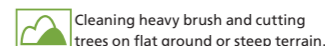
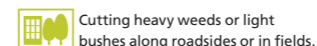
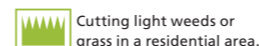

Trimmer & Brushcutter Accessories

Trimmer/Brushcutter cutting heads

● Standard ○ Option * Installable with M8 Shaft

| Product | PT104Plus Tap & Go 4" | PT104-12 Tap & Go 4" | Auto Cutter J Tap & Go 6" | Tap Head L-12 Tap & Go 6" | 2-Tooth Blade 12" | 2-Tooth Blade 12" | 3-Tooth Blade 10" | 4-Tooth Blade 9" | 4-Tooth Blade 10" | 8-Tooth Blade 9" | 8-Tooth Blade 10" | 80-Tooth Blade 10" | 40P Tip Saw 10" |
|-----------------------------|-----------------------|----------------------|---------------------------|---------------------------|-------------------|-------------------|-------------------|------------------|-------------------|------------------|-------------------|--------------------|-----------------|
| Part No. | 848BU36902 | 848JTS6903 | 604199005 | 848JTA6900 | 618915111 | 579642601 | 8488223011 | 629814244 | 629814344 | 629815244 | 629815344 | 585363201 | 584264401 |
| Cord Size / Blade thickness | ø2.4x6m | ø2.4x6m | ø2.4x14m | ø3.0x3m | 1.6mm | 1.6mm | 1.8mm | 1.4mm | 1.4mm | 1.4mm | 1.4mm | 1.4mm | 1.25mm |
| BC2611 | ● | | | | | | | ○ | ○ | | | | |
| BC3501/4501 | ○ | | ○ | | ○ | | | | | | | ○ | ○ |
| BC3401 | ○ | | ○ | | ○ | | | | | | | ○ | ○ |
| BC4301 | ○ | | ○ | | ○ | | | | | | | ○ | ○ |
| BC4500/4501 | ○ | | ○ | | ○ | | | | | | | ○ | ○ |
| BC4350DW | ○ | | ○ | | ○ | | | ○ | | | | ○ | ○ |
| BC4350FW | ○ | | ○ | | ○ | | | ○ | | | | ○ | ○ |
| BCZ5050 | | ● | | ○ | ○ | | | | | | | ○ | ○ |
| BKZ305 | | | | | ○ | | | | | | | ○ | ○ |
| BK3410/4310 | ○* | | ○ | | ○ | | | | | | | ○ | ○ |
| BK3402/4302 | | | | | ○ | ○ | | | | | | ○ | ○ |
| BK3420 | | | | | ○ | | | | | | | ○ | ○ |
| BKZ5010 | | ● | | ○ | ○ | | | ○ | ○ | | | ○ | ○ |

Option

Mounting Shaft for Tap Head
M7 : 6041-99240, M8 : 6041-99220, M10 : 6041-99230

Cutting head applications/ Working places

| Cutting head | Grass | Light weeds | Heavy weeds/pasture | Thin | Thick | Light bushes | Heavy bushes | Applications |
|----------------------------|-------|-------------|---------------------|------|-------|--------------|--------------|--------------|
| Reciprocating blade (dual) | ● | ● | ● | ● | ● | ○ | ○ | ● |
| Nylon head (2 lines) | ● | ● | ● | ● | ○ | ○ | ○ | ○ |
| Nylon head (4 lines) | ● | ● | ● | ● | ○ | ○ | ○ | ○ |
| 3-tooth blade | ○ | ○ | ○ | ○ | ○ | ○ | ○ | ○ |
| 4-tooth blade | ○ | ○ | ○ | ○ | ○ | ○ | ○ | ○ |
| 8-tooth blade | ○ | ○ | ○ | ○ | ○ | ○ | ○ | ○ |
| 2-tooth blade | ○ | ○ | ○ | ○ | ○ | ○ | ○ | ○ |



Prevent scattering of grass, stone or dust to the environment by the large-size net.

Guard Net Pro

584294601

Height : 200cm
Width : 200cm
Weight : 2.5kg
Reticulation : 0.7mm



Protect a worker from stain or flying objects during work.

Apron Pro

584294701

Height : 118cm (seat part : 40)
Width : 75cm
Weight : 270g
Reticulation : 0.7mm



Protect shin from flying objects during work.

Leg Guard Pro

584294801

Height : 30cm
Width : 14cm
Weight : 448g



Chainsaws

With the continual challenge for the innovative technology, Zenoah offers not more than the world lightest chainsaw, but performance-oriented powerful chainsaws. Combining the efficiency, reliability and durability in our feature, you will find the best solution for the various needs.



Light weight

This doesn't just apply to the world's lightest model G2000T. Every chainsaw in the ZENOAH lineup is designed based upon our accumulated know-how to be light, compact and powerful.



Powerful

The strato-charged® engine produces the optimal power to work effectively. It also meets the emission standards for less emission.

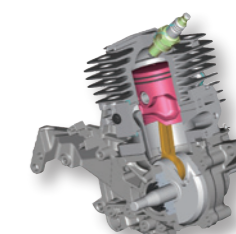

Dust-free air intake

It separates out dust using a centrifugal method and intakes only clean air. The original "dust-free" feature keeps air clean and needs maintenance far less frequently.



Easy to start

Thanks to the damper spring installed in our Super e-START, it reduces recoil pulling force and achieves smoother pulling operation. The Super e-START requires only 1/3 of the normal recoil pulling force and 1/2 of the normal recoil pulling speed.

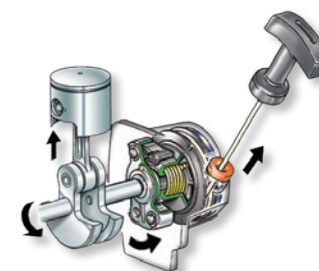

Convenient and safe

It increases the safety and stability when you work on a tree by using this "One Push Start" function.



Features shown are available on applicable models.

Chainsaws

Top-handle saws

Zenoah's top-handle saws are very easy to handle in its well balanced body. The light weight and compact design gives perfect operability for the tree care users.

G2001T

Displacement **18.3cm³**
Power 0.6kW (0.9 Hp)
Dry weight 2.3kg
20cm SP(8")

25AP G2001T SP



Compact and powerful.
Lightest in the class.

G2500T

Displacement **25.4cm³**
Power 1.0kW (1.3 Hp)CE
0.9kW (1.2 Hp)OPS
Dry weight 2.9kg CE
3.1kg OPS
25cm SP(10") / CV(10")

91PX G2500T CE / SP
G2500T OPS / SP

25AP G2500T CE / CV
G2500T OPS / CV



Convenient and safe
It increases the safety and stability when you work on a tree by using this "One Push Start" function.



NEW!

Compact and powerful.
The world's lightest.

G2050T

Displacement **18.3cm³**
Power 0.7kW (1.0 Hp)
Dry weight 2.2kg
20cm SP(8") / CV(8")

25AP G2050T SP
G2050T CV



ONLY 2.2kg!



Pruning, cross-cutting,
and removing small to medium
size branches from trees.

GZ3500T

Displacement **35.2cm³**
Power 1.5kW (2.0 Hp)
Dry weight 3.3kg
30cm SP(12") / 35cm SP(14")

91PX GZ3500T / SP



Top-handle saws

| Model | G2050T NEW! | G2001T | G2500T | | | | GZ3500T |
|------------------------------|----------------------|-------------|-----------|-------------|----------|--------------|-------------------|
| | | | CE | CE(Carving) | OPS | OPS(Carving) | |
| Displacement | cm ³ 18.3 | 18.3 | 25.4 | | | | 35.2 |
| Power | kW (Hp) 0.7 (1.0) | 0.6 (0.9) | 1.0 (1.3) | | | | 1.5 (2.0) |
| Fuel tank | lit 0.17 | 0.17 | 0.23 | | | | 0.25 |
| Oil tank | lit 0.16 | 0.16 | 0.16 | | | | 0.17 |
| Chain brake system | Manual | Auto | Auto | | | | Auto |
| Sprocket type | Spur | Spur | Spur | | | | Spur |
| Saw chain type (Oregon code) | 25AP | 25AP | 91PX | 25AP | 91PX | 25AP | 91PX |
| Chain tensioner | Side | Side | Side | | | | Side |
| Primary pump | ● | ● | ● | | | | ● |
| Compatible bar type | SP / Carving | Sprocket | Sprocket | Carving | Sprocket | Carving | Sprocket |
| Bar size | in (cm) 8 (20) | 8 (20) | 10 (25) | | | | 12 (30) / 14 (35) |
| Dry weight | kg 2.2 | 2.3 | 2.9 | | | | 3.3 |
| Dust free | ● | ● | - | - | - | - | - |
| Strato-charged engine | - | - | - | - | - | - | ● |
| Super e-start | ● (e-start) | ● (e-start) | - | - | ● | ● | ● |
| OPS | - | - | - | - | ● | ● | - |

- Non compliant ● Compliant

All-round saws

All-round chainsaws are designed for farmers and other occasional users who work less regularly but need optimum performance and better operability in its machine.

High Quality but Economy Model
for Every Use

G3800

Displacement **37.2cm³**
Power 1.7kW (2.3 Hp)
Dry weight 4.2kg
40cm SP(16")

91PX G3800 CE / SP
95VPX G3800 / SP



Light weight, high
performance model.

G4100

Displacement **40.1cm³**
Power 2.0kW (2.7 Hp)
Dry weight 4.2kg

40cm SP(16")

95VPX G4100 / SP



Low-emission and High mileage
Compact professional model

GZ4300

Displacement **43.1cm³**
Power 2.2kW (3.0 Hp)
Dry weight 4.4kg

40cm SP(16")

21BPX GZ4300 / SP



Lightest Among Long-Handle Saws

G3300

Displacement **31.8cm³**
Power 1.3kW (1.8 Hp)
Dry weight 3.5kg
35cm SP(14") / 40cm SP(16")

91VXL G3300 / SP



High Quality but Economy Model
for Every Use (equipped with priming pump)

G3802

Displacement **37.2cm³**
Power 1.6kW (2.2 Hp)
Dry weight 4.2kg
40cm SP(16")

95VPX G3802 / SP
G3802 / SP



Light weight, high
performance model.

G4101

Displacement **40.1cm³**
Power 2.0kW (2.7 Hp)
Dry weight 4.2kg

40cm SP(16")

95VPX G4101 / SP



World first Strato-Charged™ chainsaw.
High mileage, low emissions.

GZ4500

Displacement **44.0cm³**
Power 2.0kW (2.7 Hp)
Dry weight 4.3kg

40cm SP(16")

95VPX GZ4500 CE / SP



All-round saws

| Model | G3300 | G3800 | | G3802 | | G4100 | G4101 | GZ4300 | GZ4500 |
|------------------------------|---------------------------|-----------|---------|-----------|---------|-----------|-----------|-----------|-----------|
| | | G3800CE | G3800EZ | G3802 | G3802EZ | | | | |
| Displacement | cm ³ 31.8 | 37.2 | | 37.2 | | 40.1 | 40.1 | 43.1 | 44.0 |
| Power | kW (Hp) 1.3 (1.8) | 1.7 (2.3) | | 1.6 (2.2) | | 2.0 (2.7) | 2.0 (2.7) | 2.2 (3.0) | 2.0 (2.7) |
| Fuel tank | lit 0.27 | 0.31 | | 0.31 | | 0.31 | 0.31 | 0.42 | 0.31 |
| Oil tank | lit 0.20 | 0.21 | | 0.21 | | 0.21 | 0.21 | 0.27 | 0.21 |
| Chain brake system | Manual | Auto | | Auto | | Manual | Auto | Auto | Auto |
| Sprocket type | Spur | Spur | | Spur | | Spur | Spur | Rim | Spur |
| Saw chain type (Oregon code) | 91VXL | 91PX | 95VPX | 95VPX | | 95VPX | 95VPX | 21BPX | 95VPX |
| Chain tensioner | Side | Front | | Front | | Front | Front | Side | Side |
| Primary pump | ● | - | | - | | - | - | ● | - |
| Compatible bar type | Sprocket | Sprocket | | Sprocket | | Sprocket | Sprocket | Sprocket | Sprocket |
| Bar size | in (cm) 14 (35) / 16 (40) | 16 (40) | | 16 (40) | | 16 (40) | 16 (40) | 16 (40) | 16 (40) |
| Dry weight | kg 3.5 | 4.2 | | 4.2 | | 4.2 | 4.2 | 4.4 | 4.3 |
| Dust free | ● | ● | | ● | | ● | ● | ● | - |
| Strato-charged engine | - | - | | - | | - | - | ● | ● |
| Super e-start | ● | - | ● | - | ● | - | - | ● | - |

- Non compliant ● Compliant

Chainsaws

Compact professional saws

Zenoah's compact professional saws are designed for forest professionals, exacting demands of high performance, productivity and durability.

Super slim, compact body with professional grade functions.

G4501

Displacement **45.0**cm³
Power 2.1kW (2.9 Hp)
Dry weight 5.0kg
45cm SP(18")

21BPX G4501 / SP



Compact professional saws

| Model | G4501 |
|------------------------------|----------------------|
| Displacement | cm ³ 45.0 |
| Power | kW (Hp) 2.1 (2.9) |
| Fuel tank | lit 0.55 |
| Oil tank | lit 0.26 |
| Chain brake system | Auto |
| Sprocket type | Rim |
| Saw chain type (Oregon code) | 21BPX |
| Chain tensioner | Side |
| Primary pump | - |
| Compatible bar type | Sprocket |
| Bar size | in (cm) 18 (45) |
| Dry weight | kg 5.0 |
| Dust free | ● |

Robust saws

Zenoah's robust and bigger chainsaws are designed to endure the tough conditions and severe environments. These saws deliver more power and extra durability, as well as the quick maintenance feature within the machine.

Professional Saw of High Cost Performance

G5200

Displacement **49.3**cm³
Power 2.7kW (3.7 Hp)
Dry weight 4.9kg
45cm SP(18")

21BPX G5200 / SP



Professional Saw of High Cost Performance

G5201

Displacement **49.3**cm³
Power 2.7kW (3.7 Hp)
Dry weight 5.2kg
45cm SP(18")

21BPX G5201 / SP



Professional Saw of High Cost Performance

G5201P

Displacement **49.3**cm³
Power 2.6kW (3.5 Hp)
Dry weight 5.3kg
45cm SP(18")

21BPX G5201P / SP



Robust saws

| Model | G5200 | G5201 | G5201P |
|------------------------------|----------------------|-----------|-----------|
| Displacement | cm ³ 49.3 | 49.3 | 49.3 |
| Power | kW (Hp) 2.7(3.7) | 2.7 (3.7) | 2.6 (3.5) |
| Fuel tank | lit 0.55 | 0.55 | 0.55 |
| Oil tank | lit 0.26 | 0.26 | 0.26 |
| Chain brake system | Auto / Manual | Auto | Auto |
| Sprocket type | Rim | Rim | Rim |
| Saw chain type (Oregon code) | 21BPX | 21BPX | 21BPX |
| Chain tensioner | Side | Side | Side |
| Primary pump | - | - | - |
| Compatible bar type | Sprocket | Hard | Hard |
| Bar size | in (cm) 18 (45) | 18 (45) | 18 (45) |
| Dry weight | kg 5.1 / 4.9 | 5.2 | 5.2 |
| Dust free | ● | ● | ● |

- Non compliant ● Compliant

Chainsaw Bars & Chains

| Model | Length in.(mm) | Bar | | | Chain | | Sprocket | | | |
|-------------------------|----------------|----------|------------|-----------|-------------|------------|---------------|------|---------------|------------|
| | | Type | Part No. | Guage in. | Oregon code | Drive Link | Part No. | Type | Pitch & Tooth | Part No. |
| G2000T/G2001T/G2050T | 8(200) | SP | 298352111 | 0.050 | 25AP | 52 | 298152210-50 | Spur | 1/4 - 8T | 848C005112 |
| | | CV | 848CB1X021 | | | | 298152210-50 | | | |
| G2500T | 10(250) | SP | 247552111 | 0.050 | 25AP | 40 | 369992830 | Spur | 3/8 - 6T | 247551110 |
| | | CV | 247552121 | | | | 362252210-50 | | | |
| G3000T | 12(300) | SP | 848CB22G25 | 0.050 | 91PX | 45 | 369992753 | Spur | 3/8 - 6T | 287251111 |
| | | SP | 848CB24G24 | | | | 369992733 | | | |
| G3401 | 14(350) | SP | 848CB14G11 | 0.050 | 91VXL | 52 | 369992708 | Spur | 3/8 - 6T | T222051110 |
| | | SP | 848CB12G20 | | | | 369992753 | | | |
| GZ3500T | 12(300) | SP | 848CB24G30 | 0.050 | 91PX | 45 | 369992733 | Spur | 3/8 - 6T | T222051110 |
| | | SP | 848CB24G24 | | | | 369992733 | | | |
| G3800(CE) | 14(350) | SP | 848CB24G24 | 0.050 | 91PX | 52 | 369992733 | Spur | 3/8 - 6T | 286051111 |
| | | SP | 360852113 | | | | 369992752 | | | |
| G3800/G3802/GZ4000 | 16(400) | SP | 293952111 | 0.050 | 95VPX | 66 | 369992663 | Spur | 0.325 - 7T | 285151111 |
| | | SP | 293952111 | | | | 369992663 | | | |
| G4100/GZ4500 | 16(400) | SP | 293952111 | 0.050 | 95VPX | 66 | 369992663 | Spur | 0.325 - 7T | 285151111 |
| | | SP | 848CB48P11 | | | | 369992669 | | | |
| G4101 | 16(400) | SP | 293952111 | 0.050 | 95VPX | 66 | 369992663 | Spur | 0.325 - 7T | 285151111 |
| | | SP | 296652111 | | | | 848CC21B66-50 | | | |
| GZ4300 | 16(400) | SP | 296652111 | 0.058 | 21BPX | 66 | 848CC21B66-50 | Rim | 0.325 - 7T | 335051121 |
| | | SP | 364552114 | | | | 848CC21B66-50 | | | |
| G4200 | 16(400) | SP | 364552114 | 0.058 | 21BPX | 66 | 848CC21B66-50 | Rim | 0.325 - 7T | 335051121 |
| | | SP | 364652114 | | | | 848CC21B72-50 | | | |
| G4500/G4501/G5000/G5200 | 18(450) | H | 297452112 | 0.058 | 21BPX | 72 | 848CC21B72-50 | Rim | 0.325 - 7T | 335051121 |
| | | H(Light) | 587017701 | | | | 848CC21B72-50 | | | |
| G5201/G5201P | 18(450) | RSP | 297652102 | 0.058 | 21BPX | 72 | 848CC21B72-50 | Rim | 0.325 - 7T | 335051121 |
| | | H(Light) | 587017701 | | | | 848CC3LG60-50 | | | |
| G621/G6200 | 16(400) | SP | 367052113 | 0.058 | 73LGX | 60 | 848CC3LG60-50 | Rim | 3/8 - 7T | 336051120 |
| | | SP | 367352114 | | | | 848CC3LG66-50 | | | |
| | | SP | 367452114 | | | | 848CC3LG72-50 | | | |
| | | RSP | 367952103 | | | | 369992571 | | | |
| PSZ-A | 10(250) | SP | 580814301 | 0.050 | 25AP | 58 | 369991680 | Spur | 1/4 - 8T | 574865001 |

*CV : Carving, H : Hard nose, SP : Sprocket nose, RSP : Replaceable nose

RSP = Replacable Sprocket Nose bar



H = Hard Nose bar



SP = Sprocket Nose bar



CV = Carving bar



Options



Winter Cover

For running the machine in cold weather or powder snow, a special cover is available, which is mounted on the recoil case. This reduces the intake of cold air and prevents large amounts of snow from being sucked in.

| Model | Part No. |
|------------------------------|-----------|
| G2500 (Except Super e-start) | 284198330 |
| GZ4300 | 580659802 |
| G4501/G5200/G5201/G5201P | 288198611 |



Felt Cleaner

The felt type air filter prevents the reduction of engine performance due to inhalation of dusts. It is suitable for a dusty environment.

| Model | Part No. |
|--------------------------|-----------|
| GZ4300 | 285098300 |
| G4501/G5200/G5201/G5201P | 281198501 |



Blowers

Zenoah offers both backpack blowers with a professional capacity and lightweight handheld blowers for home use. They are easy to operate with high blowing capacity and bring the powerful & satisfying result.



Backpack blowers



Powerful

Zenoah blowers have a high blowing capacity with the high air speed and big volume. The strato-charged® engine produces the optimal power, while we consider the environment.



Easy Maintenance

Zenoah original free-flow net prevents clogging from leaves.



User friendly

Auto-cruse trigger maintains the optimum speed.



Durability

With large and two-stage (double) air filters, it takes less particles and dust which makes longer operating life. (EB7000 / EBZ7500 / EBZ8500)



Easy to start

"Super e-START" reduces recoil pulling force and makes it smoother in pulling operation.

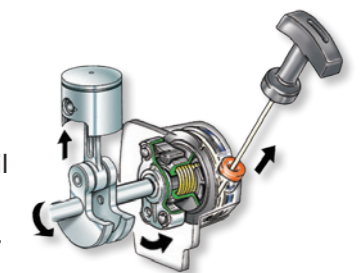

Handheld blowers

Convenience

Our handheld blowers have an "Assisted handle", which gives you a great comfort.



Features shown are available on applicable models.

Blowers

Handheld blowers

High mileage, *Storato-Charged®* handheld blower.

NEW!

HBZ260

Displacement **25.4cm³**
Power 0.85kW(1.14Hp)
Dry weight 3.7kg

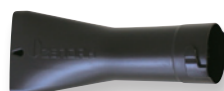

includes a flat nozzle



Less Fatigue & High Working Efficiency

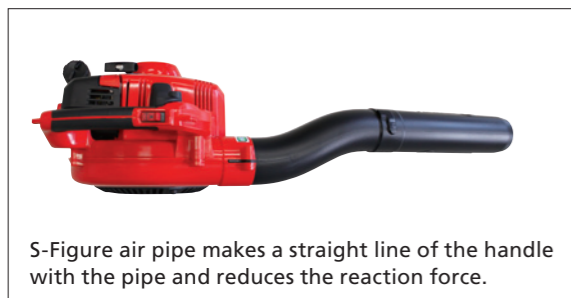

S-Figure air pipe makes a straight line of the handle with the pipe and reduces the reaction force.



Easy-Handling with Assist handle

Handheld blowers

| Model | HBZ260 NEW! |
|-----------------------|------------------------|
| Displacement | cm ³ 25.4 |
| Power | kW (Hp) 0.9 (1.2) |
| Air volume | m ³ /min 13 |
| Max air velocity | m/sec 73 |
| Dry weight* | kg 3.7 |
| Fuel tank | lit 0.45 |
| Air filter | Dry polyurethane foam |
| Standard pipe | mm ø66 |
| Super e-start | ● |
| Strato-charged engine | ● |

* Without tube

Backpack blowers

Light weight compact and powerful

EBZ3000 **CE**

Displacement **29.5cm³**
Power 0.8kW (1.1Hp)
Dry weight 6.1kg



High Mileage!



Powerful and larger air volume jet-stream, easy maneuverability.

EBZ5100

Displacement **50.2cm³**
Power 1.6kW (2.2Hp)
Dry weight 9.4kg



High Mileage! Quiet!!



Powerful and durable. Easy maneuverability.

EB6200

Displacement **62.0cm³**
Power 2.9kW (3.9Hp)
Dry weight 8.6kg

Option

Flat nozzle
848L710641



for EBZ3000
EBZ5100 / EB6200

High performance!
Large air cleaner
and large fuel tank.

EBZ7500

Displacement **65.6cm³**
Power 2.8kW (3.6Hp)
Dry weight 10.5kg



Largest Air Volume!

Most powerful.
Low emission,
durable and powerful!

EBZ8500

Displacement **75.6cm³**
Power 3.3kW (4.4Hp)
Dry weight 11.1kg



Backpack blowers

| Model | EBZ3000 | EBZ5100 | EB6200 | EBZ7500 | EBZ8500 |
|-----------------------|--------------------------|------------------------------|----------------------------|---------------------------------|---------------------------------|
| Displacement | cm ³ 29.5 | 50.2 | 62.0 | 65.6 | 75.6 |
| Power | kW (Hp) 0.8 (1.1) | 1.6 (2.2) | 2.9 (3.9) | 2.8 (3.6) | 3.3 (4.4) |
| Air volume | m ³ /min 10.6 | 13.8 | 15 | 21.8 | 25.7 |
| Max air velocity | m/sec 59 | 76.3 | 83 | 105.6 | 92.2 |
| Dry weight* | kg 6.1 | 9.4 | 8.6 | 10.5 | 11.1 |
| Fuel tank | lit 1.0 | 2.1 | 2.0 | 2.1 | 2.3 |
| Air filter | Dry polyurethane foam | Half-wet single stage filter | Half-wet polyurethane foam | 2-stage freshflow filter system | 2-stage freshflow filter system |
| Standard pipe | mm ø66 | ø66 | ø66 | ø72 | ø84 |
| Super e-start | ● | - | - | - | - |
| Strato-charged engine | ● | ● | - | ● | ● |

* Without tube

● Non compliant
● Compliant

Hedge Trimmers

For the professional looks of hedge trimming work in a garden, park, and roadside, Zenoah's well-balanced hedge trimmers become the perfect assistant for you. We have not only the heavy-duty professional models, but the light weight user-friendly models, which offer you wider alternatives.

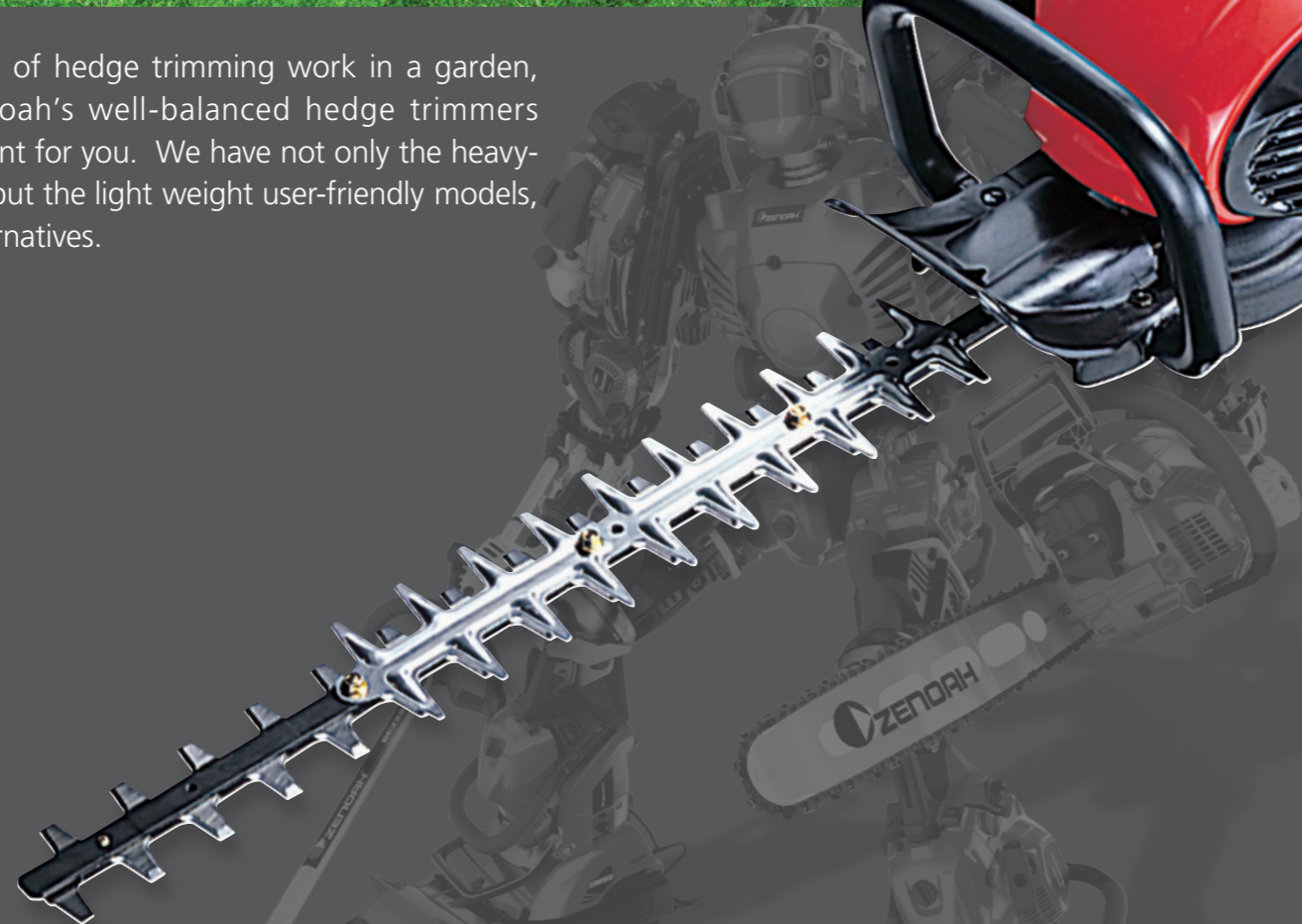
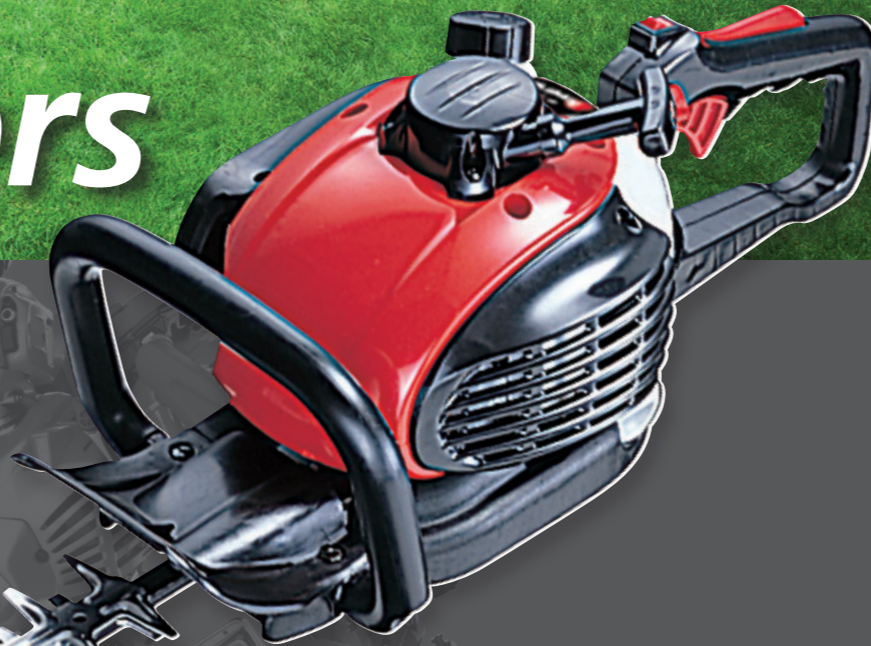

Powerful

The strato-charged® engine produces the optimal power to work effectively. It also meets the emission standards for less emission. (HTZ/CHTZ)

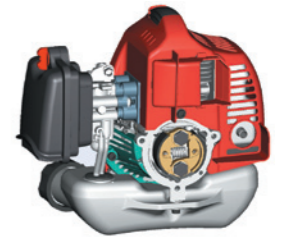

Easy maintenance

Due to gap adjusting washer and spacer, No need to adjust the blade gap.

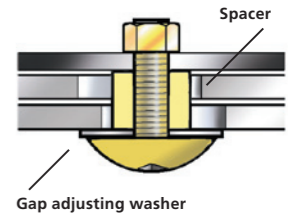

Less fatigue

Four anti-vibration points drastically reduce fatigue, as well as its noise level.

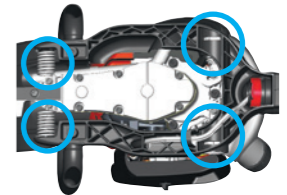

Easy to start

"e-START" reduces recoil pulling force and makes it smoother in pulling operation.

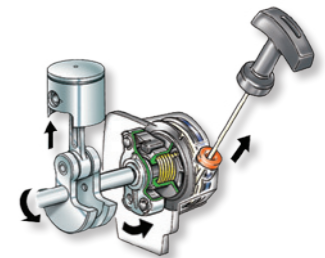

Durability

Reinforced gearcase, durable transmission with ball bearings and thicker blades bring more durability under tough conditions.

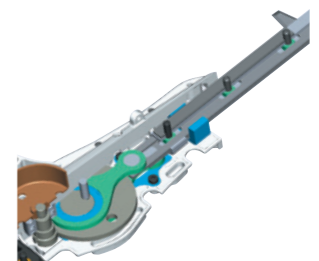

Hedge Trimmers

Single-sided hedge trimmers

The world's lightest, well-balanced hedge trimmer for light-duty users.

eHT751S

Displacement **21.7**cm³
Power 0.6kW (0.8Hp)
Dry weight 4.4kg



CE certified model.

eHT752S CE

Displacement **21.7**cm³
Power 0.7kW (0.9Hp)
Dry weight 4.7kg



Thick blades and tough body. Suitable for professionals.

HTZ7500 CE

Displacement **23.6**cm³
Power 0.8kW(1.1Hp)
Dry weight 5.9kg



Super long and tough blade for more efficiency! Ultimate model for high-demand professionals.

HTZ1000

Displacement **23.6**cm³
Power 0.8kW(1.1Hp)
Dry weight 6.4kg



Hedge trimmer blades

| Product | Upper Blade | Lower Blade | Blade Assy |
|---------|-------------|-------------|------------|
| eHT751S | T452111220 | T452111210 | 848D3D6502 |
| eHT752S | 848D3065B0 | 848D3065A0 | 848D306501 |
| HTZ7500 | | | 848D3J6501 |
| HTZ1000 | 848D5065B0 | 848D5065A0 | 848D506500 |



| Model | eHT751S | eHT752S | HTZ7500 | HTZ1000 |
|--------------------------|----------------------|------------|-------------|-------------|
| Engine model | G20LH | G20LH | GZ23N | GZ23N |
| Displacement | cm ³ 21.7 | 21.7 | 23.6 | 23.6 |
| Power | kW(Hp) 0.6 (0.8) | 0.7 (0.9) | 0.8(1.1) | 0.8(1.1) |
| Torque | N.m. kgm 0.90 (0.09) | 1.1 (0.11) | 1.23 (0.13) | 1.23 (0.13) |
| Dry weight | kg 4.4 | 4.7 | 5.9 | 6.4 |
| Fuel tank capacity | lit 0.4 | 0.4 | 0.47 | 0.47 |
| Blade length | mm 670 | 670 | 750 | 1,076 |
| Effective cutting length | mm 560 | 560 | 630 | 918 |
| Cutter pitch | mm 35 | 35 | 35 | 34 |
| Length | mm 20 | 20 | 20 | 20 |
| e-start | ● | ● | - | - |
| Strato-charged engine | - | - | ● | ● |

- Non compliant ● Compliant

Double-sided hedge trimmers

Light weight double-sided model for light-duty users.

eHT601D

Displacement **21.7**cm³
Power 0.6kW (0.8Hp)
Dry weight 4.3kg



CE certified model.

eHT602D CE

Displacement **21.7**cm³
Power 0.7kW (0.9Hp)
Dry weight 4.5kg



Professional hedge trimmer.

CHTZ6000 CE

Displacement **23.6**cm³
Power 0.8kW(1.1Hp)
Dry weight 5.8kg



Long double-blade, versatile trimmer.

CHTZ7500 CE

Displacement **23.6**cm³
Power 0.8kW(1.1Hp)
Dry weight 6.1kg



Hedge trimmer blades

| Product | Blade (2blade/unit) | Blade Assy |
|----------|---------------------|------------|
| eHT601D | T454011210 | 848D486502 |
| eHT602D | 848D3165A0 | 848D316501 |
| CHTZ6000 | | 848D4C6501 |
| CHTZ7500 | 848D4B65A0 | 848D4E6501 |

| Model | eHT601D | eHT602D | CHTZ6000 | CHTZ7500 |
|--------------------------|----------------------|-------------|-------------|-------------|
| Engine model | G20LH | G20LH | GZ23N | GZ23N |
| Displacement | cm ³ 21.7 | 21.7 | 23.6 | 23.6 |
| Power | kW(Hp) 0.6 (0.8) | 0.7 (0.9) | 0.8(1.1) | 0.8(1.1) |
| Torque | N.m. kgm 0.90 (0.09) | 0.90 (0.09) | 1.23 (0.13) | 1.23 (0.13) |
| Dry weight | kg 4.3 | 4.5 | 5.8 | 6.1 |
| Fuel tank capacity | lit 0.4 | 0.4 | 0.47 | 0.47 |
| Blade length | mm 530 | 530 | 600 | 750 |
| Effective cutting length | mm 490 | 490 | 560 | 665 |
| Cutter pitch | mm 35 | 35 | 35 | 35 |
| Length | mm 20 | 20 | 20 | 20 |
| e-start | ● | ● | - | - |
| Strato-charged engine | - | - | ● | ● |

- Non compliant ● Compliant

Work efficiency

The 180 degrees adjustable handle is very convenient when we cut both vertically and horizontally.



Multi trimmers

Lightweight multi tool trimmers for landscape professionals. You can select the engine units and attachments according to the purpose of use.

NEW!

Pipe length : 750mm
PHT750
 Displacement **21.7cm³**
 Power 0.7kW(0.9Hp)
 Dry weight 3.1kg

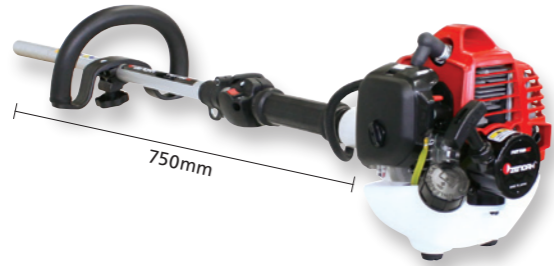

Pipe length : 1200mm
PHT1200
 Displacement **21.7cm³**
 Power 0.7kW(0.9Hp)
 Dry weight 3.2kg



Pipe length : 1500mm
PHT1500
 Displacement **21.7cm³**
 Power 0.7kW(0.9Hp)
 Dry weight 3.4kg



Long reach trimmers

| Model | PHT750 | PHT1200 | PHT1500 | |
|----------------|-----------|----------|---------|------|
| Engine model | | G20LS | | |
| Displacement | | 21.7 | | |
| Power | | 0.7(0.9) | | |
| Dry weight | 3.1 | 3.2 | 3.4 | |
| Handle | Loop | | | |
| Carburetor | Diaphragm | | | |
| Fuel Tank | lit | 0.5 | | |
| Overall length | mm | 965 | 1415 | 1715 |
| Super e-start | ● | ● | ● | |

| Recommended Attachments | PHT750 | PHT1200 | PHT1500 |
|-------------------------|--------|---------|---------|
| SHTZ-A | ● | ○ | ○ |
| LHTZ-A | ○ | ● | ○ |
| HHTZ-A | ○ | ○ | ● |
| PSZ-A | - | - | ● |

● Highly Recommended ○ Attachable - Incompatible

Attachments Adjustable angle

SHTZ-A
 Blade length : 405mm
 Dry weight : 2.0kg
 Angle : 90°

LHTZ-A
 Blade length : 405mm
 Dry weight : 1.6kg
 Angle : 90°

HHTZ-A
 Blade length : 300mm
 Dry weight : 1.4kg
 Angle : 90°

PSZ-A
 Bar : 10"
 Dry weight : 1.0kg
 Chain : Z5APJ58E

Earth Augers

Superior-performance ZENOAH augers make your pole and fence installation jobs and tree planting jobs fast and easy.

AGZ2600
 Displacement **25.4cm³**
 Power 1.0kW(1.3HP)
 Dry Weight 5.4kg

AGZ4000
 Displacement **40.1cm³**
 Power 1.5kW(2.0HP)
 Dry Weight 9.2kg

AGZ5010 CE
 Displacement **50.6cm³**
 Power 2.3kW(3.1HP)
 Dry Weight 10.4kg

| Model | AGZ2600 | AGZ4000 | AGZ5010 | |
|-----------------------|-----------------|------------|------------|------------|
| Engine Model | GZ26S | GZ40N | GZ50N | |
| Displacement | cm ³ | 25.4 | 40.1 | 50.6 |
| Power | kW (Hp) | 1.0 (1.3) | 1.5 (2.0) | 2.3 (3.1) |
| Torq | (N.m kgm) | 1.2 (0.12) | 2.0 (0.20) | 2.8 (0.29) |
| Dry weight | kg | 5.4 | 9.2 | 10.4 |
| Carburetor | Diaphragm | Diaphragm | Diaphragm | |
| Fuel tank capacity | lit | 0.68 | 0.73 | 1.0 |
| Transmission | SPUR GEAR | Worm gears | Worm gears | |
| Rated drill speed | rpm | 155 | 155 | 210 |
| Super e-start | ● | ● | ● | |
| Strato-charged engine | ● | ● | ● | |

Auger drills

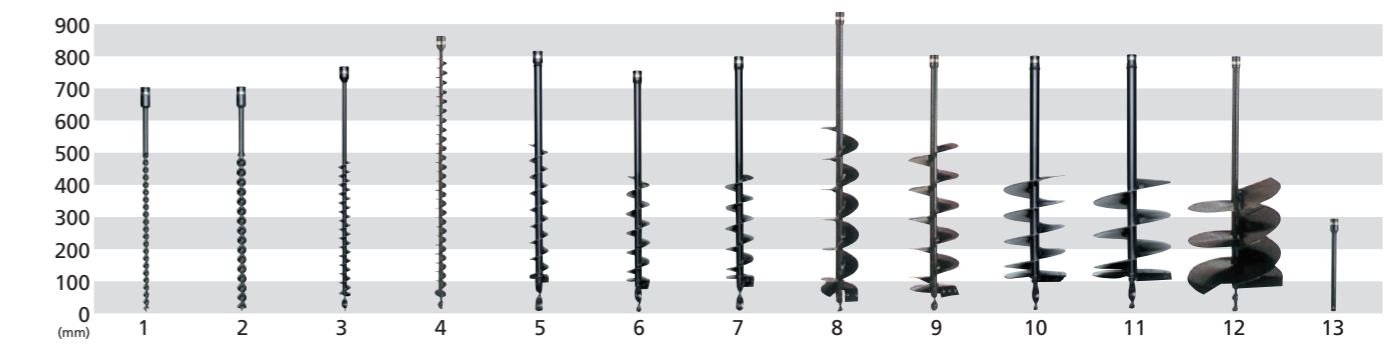

| No. | Product | Accessory code | Size | Model | | |
|-----|------------|----------------|------------------|---------|---------|---------|
| | | | | AGZ2600 | AGZ4000 | AGZ5010 |
| 1 | DRILL S20 | Z3206-52700000 | φ 20mm x L700mm | ○ | ○ | ○ |
| 2 | DRILL S30 | Z3206-52800000 | φ 30mm x L700mm | ○ | ○ | ○ |
| 3 | DRILL S40 | Z3202-51102000 | φ 40mm x L750mm | ○ | ○ | ○ |
| 4 | DRILL S40L | Z3206-51100000 | φ 40mm x L850mm | ○ | ○ | ○ |
| 5 | DRILL S60 | Z3206-52100000 | φ 60mm x L800mm | ○ | ○ | ○ |
| 6 | DRILL S80 | Z3206-52600000 | φ 80mm x L760mm | ○ | ○ | ○ |
| 7 | DRILL S90 | Z3206-52200000 | φ 90mm x L800mm | ○ | ○ | ○ |
| 8 | DRILL S120 | Z3206-52900000 | φ 120mm x L930mm | ○ | ○ | ○ |
| 9 | DRILL S150 | Z3206-52300000 | φ 150mm x L800mm | ○ | ○ | ○ |
| 10 | DRILL S200 | Z3206-52400000 | φ 200mm x L800mm | ○ | ○ | ○ |
| 11 | DRILL S250 | Z3206-52500000 | φ 250mm x L800mm | ○ | ○ | ○ |
| 12 | DRILL S300 | Z3206-53300000 | φ 300mm x L800mm | ○ | ○ | ○ |
| 13 | JOINT 300 | Z3204-53200000 | Extension 300mm | ○ | ○ | ○ |

⚠ Caution

PHT750 and PHT1200 have shorter pipe than normal trimmers. For your own safety, please do not attach trimmer/brushcutter cutting heads to these models.

Dusters/Misters

Behind each duster/mister is a wide range of unique user friendly features, incorporating reliability and compact mobility to complete the job more quickly and easily.

Light weight and comfort in a high performance package.

MD431A CE

Displacement **41.5cm³**
Power 1.5kW(2.0Hp)
Dry Weight 10.2kg



MD431M CE

Displacement **41.5cm³**
Power 1.5kW(2.0Hp)
Dry Weight 9.3kg



Exciting power and performance with a 62 cc engine. (Optional mist kit available.)

MD6210

Displacement **62.0cm³**
Power 2.8kW(3.8Hp)
Dry Weight 12.0kg



Option
Mist kit
for MD6210



NEW!

Specially designed water-spraying mister.

MD7000M

Displacement **62.0cm³**
Power 2.8kW(3.8Hp)
Dry Weight 12.7kg



| Model | MD431A | MD431M | MD6210 | MD7000M NEW! |
|---------------|----------------------|-----------|-------------|---------------------|
| Displacement | cm ³ 41.5 | 41.5 | 62.0 | 62.0 |
| Power | kW (Hp) 1.5 (2.0) | 1.5 (2.0) | 2.8 (3.8) | 2.8 (3.8) |
| Dry weight* | kg 10.2 | 9.3 | 12.0 | 12.7 |
| Caburetor | Diaphragm | Diaphragm | Circulation | Diaphragm |
| Fuel tank | lit 2.0 | 2.0 | 1.8 | 1.8 |
| Tank capacity | lit 23 | 14 | 28 | 18 |
| Discharge | Powder kg/min 6 | - | 7 | - |
| | Granule kg/min 15 | - | 14 | - |
| | Water kg/min 4 | 4 | - | 4 |
| Decomp | - | - | - | ● |

* Without tube

Power Sprayers

ZENOAH power sprayers are designed to improve speed and job efficiency in daily plant care work.

| Model | NS3526S |
|----------------------|-----------------------|
| Engine Model | G26LS |
| Displacement | cm ³ 25.4 |
| Power | kW (Hp) 0.8 (1.1) |
| Dry weight | kg 9.8 |
| Carburetor | Diaphragm |
| Fuel tank | lit 0.6 |
| Pump type | Plunger |
| Container capacity | lit 25 |
| Discharge capability | lit/min 4.8 |
| Max spray output | kg/cm ² 35 |

High-pressure plunger pump.

NS3526S

Displacement **25.4cm³**
Power 0.8kW(1.1Hp)
Dry Weight 9.8kg



Chippers Shredders

The SR series chipper shredders are designed for volume reduction and recycling of pruned branches and other vegetable wastes from planting development and land reclamation activities. The standard "auto-feed control" maximizes the crushing efficiency of trees into chips that may be used for making dairy farm cushion, mulching material, culture medium, charcoal, compost pile, and many other products.

NEW!

SR3100

Engine output 18.4kW(25.0Hp)



Bamboo Crushable

| Model | SR3100 NEW! |
|-----------------------|---------------------------|
| Weight | kg 1,330 |
| Dimension (L x W x H) | m 3.1 x 1.1 x 1.9 |
| Engine | Water-cooled diesel |
| Engine type | Yanmar 3TNV88 |
| Engine output | kW (Hp) 18.4 (25.0) |
| Chipper blade | pcs 2 |
| Shredder knife | pcs 12 |
| Limb dia. (max.) | mm 200 |
| Crushing vol. (max.) | m ³ /h 1.5 - 5 |
| Driving crawler | Rubber crawler |

Discharge Duct Options

Lower Duct
(1,580mm)



Lowest Duct
(1,380mm)



Watery Wood Use Duct
(1,680mm)



Flail Mowers

Flail mowers in the ZHM series are crawler mowers for high-stability work in riverbanks, parks, or open land. The combination of the high-power engine and the single-lever operated HST drive system makes work easy and even pleasant.

Reversible Flail Mower

ZHM1550RR

Power output 27.5kW (37.4Hp)



NEW!

Powerful and easy to operate for quickly mowing large areas.

ZHM1550

Power output 27.5kW (37.4Hp)



NEW!

Two-way grass raker AH2020R

Step-less speed control always allows the optimum speed for specific work conditions. To maximize efficiency, the reverse control turns the tine direction at the end of a run to gather grass on the same side as the run just finished.

AH2050R

| Model | ZHM1550RR NEW! | ZHM1550 NEW! |
|-----------------------|--------------------------|--------------------------|
| Cut width | mm 1,525 | 1,525 |
| Cut height | mm 0 - 300 | 0 - 300 |
| Knife | pcs 108 | 108 |
| Dimension (L x W x H) | m 3.0 x 1.7 x 1.4 | 3.0 x 1.7 x 1.4 |
| Weight | kg 1,670 | 1,600 |
| Engine | Water-cooled diesel | Water-cooled diesel |
| Output | kW (Hp) 27.5 (37.4) | 27.5 (37.4) |
| Travel speed | Forward : 7, Reverse : 5 | Forward : 7, Reverse : 5 |

* This product may not be sold in some areas.



Gathering Gathered to a side by AH2020R (for rolling)

* Pictured here mounted to the base tractor.

| Model | AH2050R |
|-----------------------|----------------------------|
| Applicable mower | ZHM1550 |
| Collecting width | mm 2000 |
| Collecting direction | Left and Right |
| Tine: Shape | Coil type double tine |
| Number | 36 (12pcs/ line x 3 lines) |
| Tilt(left/right) | 10/48 |
| Dimension (L x W x H) | m 1.1 x 2.2 x 1.1 |
| Weight | kg 1510 |

Accessories

ZENOAH GENUINE PROTECTIVE CLOTHING & PROTECTIVE ITEMS

Forestry jacket, in 4-way stretch material, which is more tear resistant than our former forestry jacket giving great comfort, superb fit and excellent ventilation. The jacket has several practical pockets with zips, a draw cord around the waist and collar with ribbed lining. Reinforced with Aramid fibre in exposed places.

Forestry Jacket Pro



| Size | XS/42 | S/46 | M/50 | L/54 |
|----------------|-----------|-----------|-----------|-----------|
| Part No. | 580400842 | 580400846 | 580400850 | 580400854 |
| Chest cm | 84-88 | 92-96 | 100-104 | 108-112 |
| Body height cm | 170-176 | 170-176 | 176-182 | 182-188 |

Size shown above is only a guide.



These protective trousers are made in the same tear resistant 4-way stretch material as the forestry jacket. Reinforced in the lower front of the trousers with Cordura®, and at the knees with Aramid for extra protection against wear. The rear of the trousers has ventilation zippers and back pockets with mesh material that gives good ventilation. The trousers use a lighter saw protection material and have a cut that makes them extremely comfortable. Wide elasticated waist and extended back. Zipped pockets front and back. Conforms to EN 381. Class 1, 20mls



Protective Trousers Pro



The saw protection consists of a lining with long fibres. If the saw chain cuts through the outer fabric, the fibres get tangled up in the chain.

Ventilation zippers at the back of legs for all day comfort.

The EuroTest label means that randomly selected garments are tested by competent, independent third party expert that has reviewed that the CE-mark on the product is fully justified.

| Size | XS/46 | S/48 | M/50 | M-W/51 | L/52 |
|---------------------|-----------|-----------|-----------|-----------|-----------|
| Type | Regular | Regular | Regular | Wide | Regular |
| Part No. | 580400746 | 580400748 | 580400750 | 580400751 | 580400752 |
| Waist, stretched cm | 80 | 84 | 88 | 92 | 92 |
| Waist, relaxed cm | 88 | 92 | 96 | 100 | 100 |
| Hip breadth cm | 96 | 100 | 106 | 110 | 110 |
| Inseam of leg cm | 74 | 77 | 79 | 79 | 81 |
| Length cm | 106 | 109 | 111 | 111 | 113 |

Size shown above is only a guide.

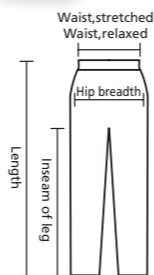

Complete with Zenoah Pro-visor with only 20% light reduction sun peak, earmuffs and neck protector. Lining and earmuffs adjust vertically and laterally. Conforms to EN397 (Helmet) and EN342-3 (Earmuffs)



Forestry Helmet Pro

580463201

Perfect to use when performing light trimmer work. Extra wide headband for secure and comfortable fit and less pressure on head. Conforms to EN166(Visor) and EN352-1(Earmuffs)



Earmuffs with perspex visor

580463301

Chaps

2 points strapped quick-release type protective pad

| Size | M | L | LL |
|-----------|-------------|-------------|--------------|
| Part No. | 369992274-M | 369992274-L | 369992274-LL |
| Waist cm | 115 | | |
| Length cm | 80 | 85 | 90 |
| Weight g | 740 | 780 | 920 |



Suspenders

Extra wide Suspenders with adjustable length. with strong metal clips.

580463501



Antivibration Gloves

369992262



Gloves

M 369992088
L 369992089
LL 369992104



FD Class 2-Stroke Engine Oil

Higher Lubricity & Detergency, Engine Friendly, High performance even in the severe environment

FD Class 50:1



1L (20pcs/carton)

4L (6pcs/carton)
includes a 20cc measuring cup

Genuine Chain Oil

Higher viscosity, Well adherent to chain, Minimizes oil spreading

Z2-1L Normal Chain Oil (20pcs/carton)



Higher viscosity, Well adherent to chain, Minimizes oil spreading

Z2-4L Normal Chain Oil (6pcs/carton)



Canola based, High degradable in the soil

VZ1-4L Vegetable Origin Chain Oil (6pcs/carton)



Fuel Mixing & Measuring Tank

Useful for mixing gasoline and engine oil

3.5L Tank

369991970A

Nozzle

369992056

